

Operating Instructions

Process pressure transmitter IPT-1*

GB

Profibus PA
Version 2.0



Process pressure transmitter IPT-1*

WIKAI

 Part of your business

Contents

1	About this document	
1.1	Function	4
1.2	Target group	4
1.3	Symbolism used.....	4
2	For your safety	
2.1	Authorised personnel	5
2.2	Appropriate use.....	5
2.3	Warning about incorrect use.....	5
2.4	General safety instructions	5
2.5	Safety label on the instrument	5
2.6	CE conformity.....	6
2.7	Measuring range - permissible process pressure	6
2.8	Fulfillment of NAMUR recommendations	6
2.9	Safety instructions for Ex areas	6
3	Product description	
3.1	Configuration.....	7
3.2	Principle of operation.....	8
3.3	Adjustment	9
3.4	Packaging, transport and storage.....	9
4	Mounting	
4.1	General instructions	11
4.2	Mounting steps.....	12
5	Connecting to power supply	
5.1	Preparing the connection	14
5.2	Connection procedure.....	15
5.3	Single chamber housing.....	16
5.4	Double chamber housing	16
5.5	Double chamber housing Ex d	18
5.6	Wiring plan, external housing with version IP 68.....	20
5.7	Switch-on phase.....	21
6	Set up with the display and adjustment module	
6.1	Short description	23
6.2	Insert display and adjustment module	23
6.3	Adjustment system	24
6.4	Menu schematic.....	25
6.9	Saving the parameter adjustment data.....	27
7	Setup with PDM	
7.1	Parameter adjustment with PDM	28
8	Maintenance and fault rectification	
8.1	Maintenance	29
8.2	Rectify faults.....	29
8.3	Instrument repair	30
9	Dismounting	
9.1	Dismounting steps.....	32
9.2	Disposal	32

10 Supplement

10.1	Technical data	33
10.2	Information on Profibus PA	41
10.3	Dimensions	45

Supplementary documentation



Information:

Supplementary documents appropriate to the ordered version come with the delivery. You can find them listed in chapter "*Product description*".

Editing status: 2013-06-05

1 About this document

1.1 Function

This operating instructions manual provides all the information you need for mounting, connection and setup as well as important instructions for maintenance and fault rectification. Please read this information before putting the instrument into operation and keep this manual accessible in the immediate vicinity of the device.

1.2 Target group

This operating instructions manual is directed to trained specialist personnel. The contents of this manual should be made available to these personnel and put into practice by them.

1.3 Symbolism used



Information, tip, note

This symbol indicates helpful additional information.



Caution: If this warning is ignored, faults or malfunctions can result.

Warning: If this warning is ignored, injury to persons and/or serious damage to the instrument can result.

Danger: If this warning is ignored, serious injury to persons and/or destruction of the instrument can result.



Ex applications

This symbol indicates special instructions for Ex applications.



List

The dot set in front indicates a list with no implied sequence.



Action

This arrow indicates a single action.



Sequence of actions

Numbers set in front indicate successive steps in a procedure.



Battery disposal

This symbol indicates special information about the disposal of batteries and accumulators.

2 For your safety

2.1 Authorised personnel

All operations described in this operating instructions manual must be carried out only by trained specialist personnel authorised by the plant operator.

During work on and with the device the required personal protective equipment must always be worn.

2.2 Appropriate use

IPT-1* Vers. 2.0 is a pressure transmitter for measurement of gauge pressure, absolute pressure and vacuum.

You can find detailed information on the application range in chapter "*Product description*".

Operational reliability is ensured only if the instrument is properly used according to the specifications in the operating instructions manual as well as possible supplementary instructions.

For safety and warranty reasons, any invasive work on the device beyond that described in the operating instructions manual may be carried out only by personnel authorised by the manufacturer. Arbitrary conversions or modifications are explicitly forbidden.

2.3 Warning about incorrect use

Inappropriate or incorrect use of the instrument can give rise to application-specific hazards, e.g. vessel overfill or damage to system components through incorrect mounting or adjustment.

2.4 General safety instructions

This is a high-tech instrument requiring the strict observance of standard regulations and guidelines. The user must take note of the safety instructions in this operating instructions manual, the country-specific installation standards as well as all prevailing safety regulations and accident prevention rules.

The instrument must only be operated in a technically flawless and reliable condition. The operator is responsible for trouble-free operation of the instrument.

During the entire duration of use, the user is obliged to determine the compliance of the necessary occupational safety measures with the current valid rules and regulations and also take note of new regulations.

2.5 Safety label on the instrument

The safety approval markings and safety tips on the device must be observed.

2.6 CE conformity

The device fulfills the legal requirements of the applicable EC guidelines. By affixing the CE marking, we confirm successful testing of the product.

2.7 Measuring range - permissible process pressure

Due to the application, a measuring cell with a measuring range higher than the permissible pressure range of the process fitting may have been integrated. The permissible process pressure is stated with "Process pressure" on the type label, see chapter 3.1 "*Configuration*". For safety reasons, this range must not be exceeded.

2.8 Fulfilment of NAMUR recommendations

NAMUR is the automation technology user association in the process industry in Germany. The published NAMUR recommendations are accepted as the standard in field instrumentation.

The device fulfills the requirements of the following NAMUR recommendations:

- NE 21 – Electromagnetic compatibility of equipment
- NE 43 – Signal level for malfunction information from measuring transducers
- NE 53 – Compatibility of field devices and display/adjustment components

For further information see www.namur.de.

2.9 Safety instructions for Ex areas

Please note the Ex-specific safety information for installation and operation in Ex areas. These safety instructions are part of the operating instructions manual and come with the Ex-approved instruments.

3 Product description

3.1 Configuration

Scope of delivery

The scope of delivery encompasses:

- IPT-1* Vers. 2.0 pressure transmitter
- Documentation
 - this operating instructions manual
 - Test certificate for pressure transmitters
 - Operating instructions manual "*Display and adjustment module*" (optional)
 - Supplementary instructions manual "*Plug connector for continuously measuring sensors*" (optional)
 - Ex-specific "*Safety instructions*" (with Ex versions)
 - if necessary, further certificates

Constituent parts

The IPT-1* Vers. 2.0 consists of the components:

- Process fitting with measuring cell
- Housing with electronics, optionally available with plug connector
- Housing cover, optionally available with display and adjustment module

The components are available in different versions.

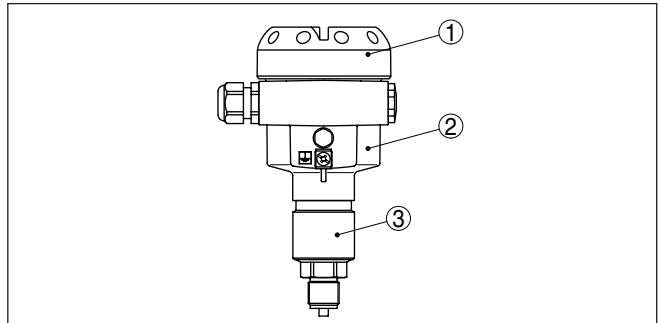

Fig. 1: Example of a IPT-1* Vers. 2.0 with manometer connection G $\frac{1}{2}$ A according to EN 837 and plastic housing

- 1 Housing cover with integrated display and adjustment module (optional)
- 2 Housing with electronics
- 3 Process fitting with measuring cell

Type plate

The nameplate contains the most important data for identification and use of the instrument:

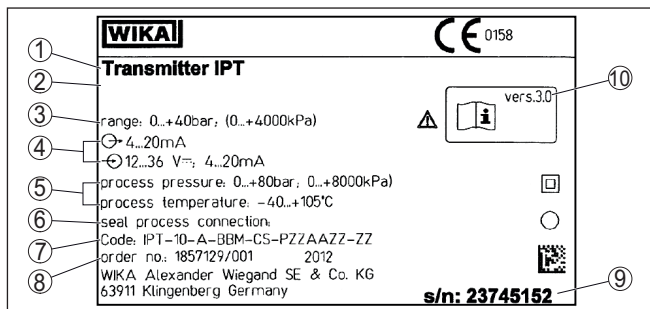

Fig. 2: Layout of the type label (example)

- 1 Instrument type
- 2 Approvals
- 3 Measuring range
- 4 Electronics
- 5 Process pressure
- 6 Seal material/Process temperature
- 7 Product code
- 8 Order number
- 9 Serial number of the instrument
- 10 ID numbers, instrument documentation

Scope of this operating instructions manual

This operating instructions manual applies to the following instrument versions:

- Software from 3.82.

3.2 Principle of operation

Application area

IPT-1* Vers. 2.0 is a pressure transmitter for use in the paper, food processing and pharmaceutical industries as well as in water/sewage water plants. Depending on the version, it is used for level, gauge, absolute pressure or vacuum measurement. Measured products are gases, vapours and liquids, also those containing abrasive substances.

Functional principle

The sensor element is a measuring cell with robust, front-flush (depending on the process fitting), abrasion-resistant ceramic diaphragm. The process pressure causes a capacitance change in the measuring cell via the ceramic diaphragm. This change is converted into an appropriate output signal and outputted as measured value. The measuring cell is also equipped with a temperature sensor. The temperature value can be displayed via the display and adjustment module as well as processed via the signal output (with digital versions).

Seal concept

As a standard feature, the ceramic measuring cell is equipped with a lateral, recessed seal.

Instruments with double seal have an additional front seal.

Instruments with hygienic fitting are equipped with a gap-free form seal.

Power supply and bus communication

Power supply via the Profibus DP/PA segment coupler. A two-wire cable according to Profibus specification serves as carrier of both power and digital data transmission for multiple sensors. The instrument profile of IPT-1* Vers. 2.0 corresponds to profile specification version 3.0.

GSD/EDD

The GSD (instrument master files) and bitmap files necessary for planning your Profibus DP (PA) communication network are available from the download section on the WIKA homepage www.wika.com under "Service". There you can also find the appropriate certificates. In a PDM environment, an EDD (Electronic Device Description) is also required to enable the full range of sensor functions (also available as a download). A CD with the appropriate files can be ordered via e-mail or by phone from one of the WIKA agencies.

The backlight of the display and adjustment module is powered by the sensor. Prerequisite is a certain level of operating voltage.

The data for power supply are specified in chapter "Technical data".

3.3 Adjustment

The instrument can be adjusted with the following adjustment media:

- With the display and adjustment module
- with the adjustment program PDM

The entered parameters are generally saved in the IPT-1* Vers. 2.0, optionally also in the display and adjustment module or in the adjustment program.

3.4 Packaging, transport and storage

Packaging

Your instrument was protected by packaging during transport. Its capacity to handle normal loads during transport is assured by a test based on ISO 4180.

The packaging of standard instruments consists of environment-friendly, recyclable cardboard. For special versions, PE foam or PE foil is also used. Dispose of the packaging material via specialised recycling companies.

Transport

Transport must be carried out under consideration of the notes on the transport packaging. Nonobservance of these instructions can cause damage to the device.

Transport inspection

The delivery must be checked for completeness and possible transit damage immediately at receipt. Ascertained transit damage or concealed defects must be appropriately dealt with.

Storage

Up to the time of installation, the packages must be left closed and stored according to the orientation and storage markings on the outside.

Unless otherwise indicated, the packages must be stored only under the following conditions:

- Not in the open

Storage and transport temperature

- Dry and dust free
- Not exposed to corrosive media
- Protected against solar radiation
- Avoiding mechanical shock and vibration
- Storage and transport temperature see chapter "*Supplement - Technical data - Ambient conditions*"
- Relative humidity 20 ... 85 %

4 Mounting

4.1 General instructions

Suitability for the process conditions

Make sure that all parts of the instrument coming in direct contact with the process, especially the sensor element, process seal and process fitting, are suitable for the existing process conditions, such as process pressure, process temperature as well as the chemical properties of the medium.

You can find the specifications in chapter "*Technical data*" and on the nameplate.

Installation position

Select an installation position you can easily reach for mounting and connecting as well as later retrofitting of a display and adjustment module. The housing can be rotated by 330° without the use of any tools. You can also install the display and adjustment module in four different positions (each displaced by 90°).

Moisture

Use the recommended cables (see chapter "*Connecting to power supply*") and tighten the cable gland.

You can give your instrument additional protection against moisture penetration by leading the connection cable downward in front of the cable entry. Rain and condensation water can thus drain off. This applies mainly to outdoor mounting as well as installation in areas where high humidity is expected (e.g. through cleaning processes) or on cooled or heated vessels.

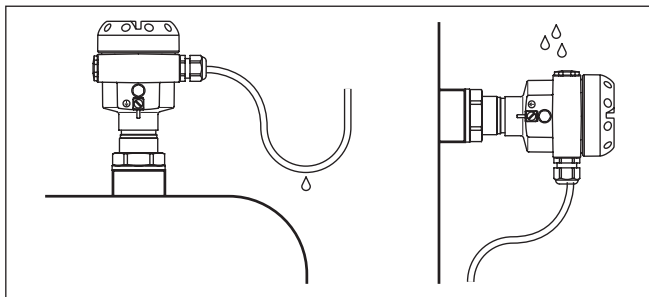

Fig. 3: Measures against moisture penetration

Ventilation and pressure compensation

The ventilation of the electronics housing as well as the atmospheric pressure compensation for the measuring cell are realised via a filter element in the area of the cable gland.

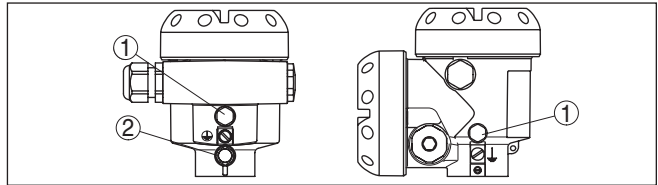

Fig. 4: Position of the filter element

- 1 Filter element
- 2 Blind plug



Caution:

Due to the filter effect, the pressure compensation is time delayed. When opening/closing the housing cover quickly, the measured value can change for a period of approx. 5 s by up to 15 mbar.



Information:

Make sure that the filter element is always free of buildup during operation. A high-pressure cleaner may not be used for cleaning.

With instrument versions in protection IP 66/IP 68, 1 bar, the ventilation is realised via the capillaries in the permanently connected cable. The filter element is replaced by a blind plug.

Temperature limits

Higher process temperatures often mean also higher ambient temperatures. Make sure that the upper temperature limits stated in chapter "Technical data" for the environment of the electronics housing and connection cable are not exceeded.

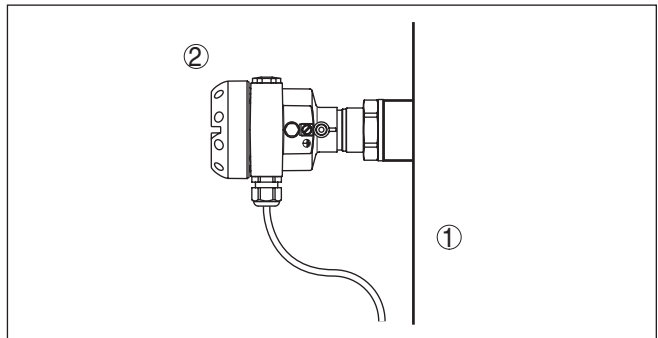

Fig. 5: Temperature ranges

- 1 Process temperature
- 2 Ambient temperature

4.2 Mounting steps

Welding the socket

For mounting IPT-1* Vers. 2.0, a welded socket is required. You can find these components in the supplementary instructions manual "Welded socket and seals".

Sealing/Screwing in threaded versions

Use the seal fitting belonging to the instrument, or in case of NPT connections, a high-resistance sealing material.

→ Screw IPT-1* Vers. 2.0 into the welded socket. Tighten the hexagon on the process fitting with a suitable wrench. Wrench size, see chapter "*Dimensions*".



Warning:

The housing must not be used to screw the instrument in! Applying tightening force can damage internal parts of the housing.

Sealing/Screwing in hygienic fittings

Use the seal suitable for the respective process fitting. You can find the components in the supplementary instructions manual "*Welded socket and seals*".

5 Connecting to power supply

5.1 Preparing the connection

Note safety instructions

Always keep in mind the following safety instructions:

- Connect only in the complete absence of line voltage
- If voltage surges are expected, overvoltage arresters should be installed according to Profibus specifications

Take note of safety instructions for Ex applications



In hazardous areas you must take note of the respective regulations, conformity and type approval certificates of the sensors and power supply units.

Select power supply

Power is supplied via a Profibus DP/PA segment coupler. The power supply range can differ depending on the instrument version. The exact range is stated in the "Technical data".

Select connection cable

IPT-1* Vers. 2.0 is connected with screened cable according to the Profibus specification. Power supply and digital bus signal are carried over the same two-wire connection cable.

Use cable with round cross-section. A cable outer diameter of 5 ... 9 mm (0.2 ... 0.35 in) ensures the seal effect of the cable gland. If you are using cable with a different diameter or cross-section, exchange the seal or use a suitable cable gland.

Please make sure that your installation is carried out according to the Profibus specification. In particular, make sure that the termination of the bus is done with appropriate terminating resistors.

Cable screening and grounding

With systems with potential equalisation, connect the cable screen directly to ground potential at the power supply unit, in the connection box and at the sensor. The screen in the sensor must be connected directly to the internal ground terminal. The ground terminal outside on the housing must be connected to the potential equalisation (low impedance).

In systems without potential equalisation, connect the cable screen directly to ground potential at the power supply unit and at the sensor. In the connection box or T-distributor, the screen of the short stub to the sensor must not be connected to ground potential or to another cable screen. The cable screens to the power supply unit and to the next distributor must be connected to each other and also connected to ground potential via a ceramic capacitor (e.g. 1 nF, 1500 V). The low frequency potential equalisation currents are thus suppressed, but the protective effect against high frequency interference signals remains.



The total capacitance of the cable and of all capacitors must not exceed 10 nF in Ex applications.

Select connection cable for Ex applications



Take note of the corresponding installation regulations for Ex applications. In particular, make sure that no potential equalisation currents flow over the cable screen. In case of grounding on both sides this can be achieved by the use of a capacitor or a separate potential equalisation.

Single/Double chamber housing**5.2 Connection procedure**

Proceed as follows:

1. Unscrew the housing cover
2. If a display and adjustment module is installed, remove it by turning it to the left.
3. Loosen compression nut of the cable entry
4. Remove approx. 10 cm of the cable mantle, strip approx. 1 cm insulation from the individual wires
5. Insert the cable into the sensor through the cable entry
6. Lift the opening levers of the terminals with a screwdriver (see following illustration)
7. Insert the wire ends into the open terminals according to the wiring plan
8. Press down the opening levers of the terminals, you will hear the terminal spring closing
9. Check the hold of the wires in the terminals by lightly pulling on them
10. Connect the screen to the internal ground terminal, connect the outer ground terminal to potential equalisation
11. Tighten the compression nut of the cable entry. The seal ring must completely encircle the cable
12. Screw the housing cover back on

The electrical connection is hence finished.

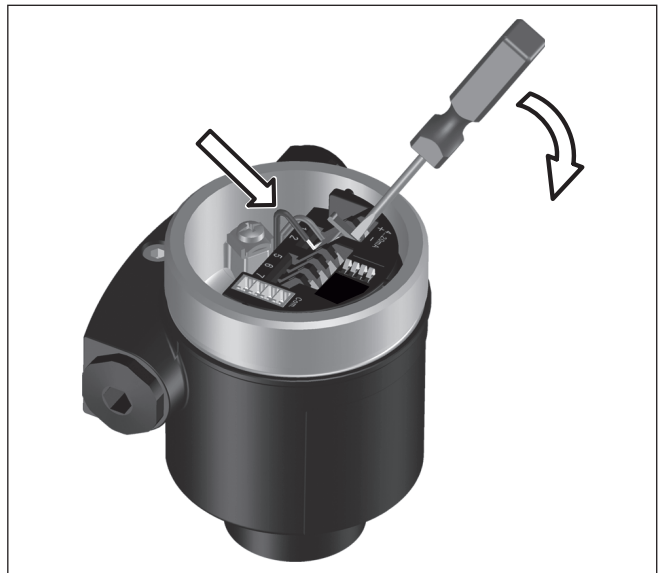

Fig. 6: Connection steps 6 and 7

5.3 Single chamber housing



The following illustrations apply to the non-Ex as well as to the Ex-ia version.

Electronics and connection compartment

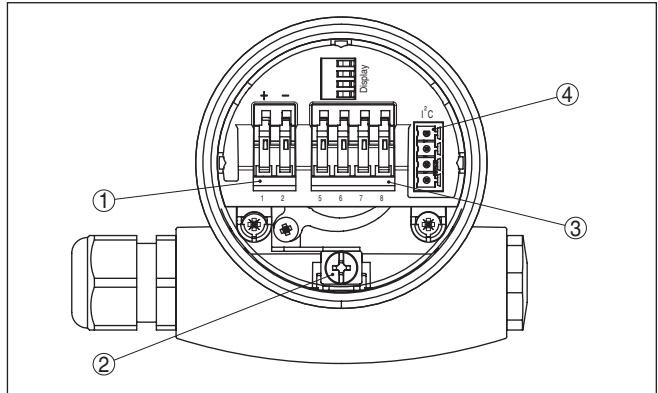

- 1 Spring-loaded terminals for voltage supply
- 2 Ground terminal for connection of the cable screen
- 3 Spring-loaded terminals for connection of the external display and adjustment unit
- 4 Plug connector for service interface

Wiring plan

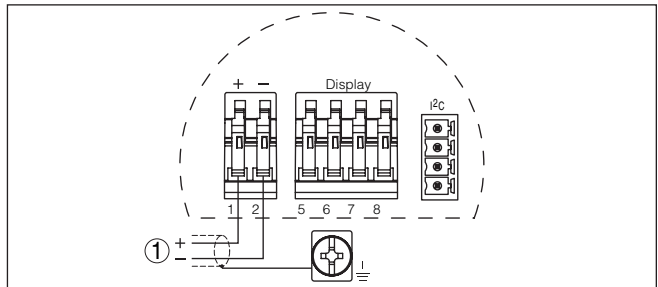

Fig. 8: Wiring plan, single chamber housing

- 1 Voltage supply, signal output

5.4 Double chamber housing



The following illustration apply to non-Ex as well as Ex ia versions. The Exd version is described in the next subchapter.

Electronics compartment

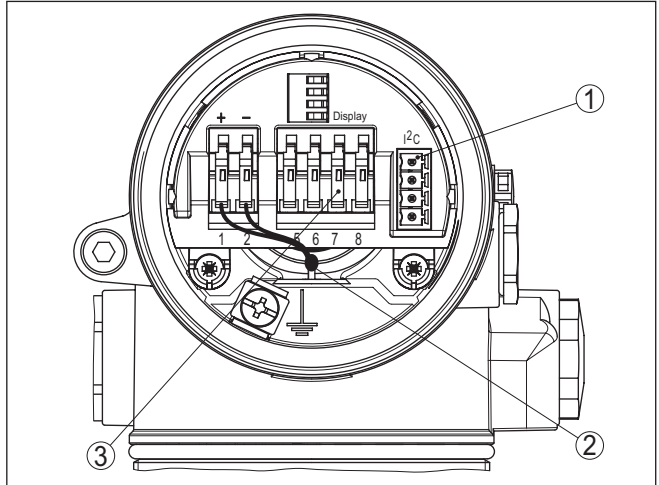

Fig. 9: Electronics compartment, double chamber housing

- 1 Plug connector for service interface
- 2 Internal connection cable to the connection compartment
- 3 Terminals for the external display and adjustment unit

Connection compartment

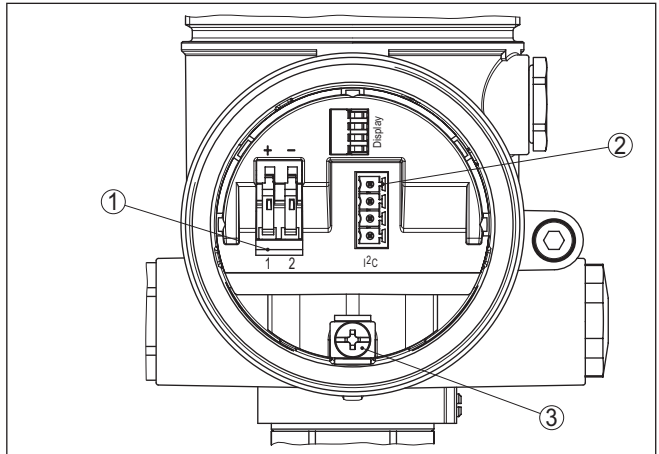

Fig. 10: Connection compartment, double chamber housing

- 1 Spring-loaded terminals for voltage supply
- 2 Plug connector for service interface
- 3 Ground terminal for connection of the cable screen

Wiring plan

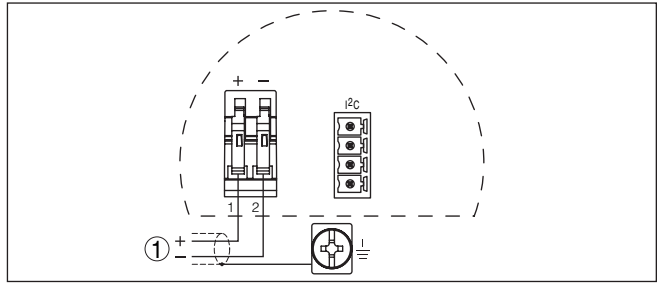

Fig. 11: Wiring plan, double chamber housing

- 1 Voltage supply, signal output

5.5 Double chamber housing Ex d

Electronics compartment

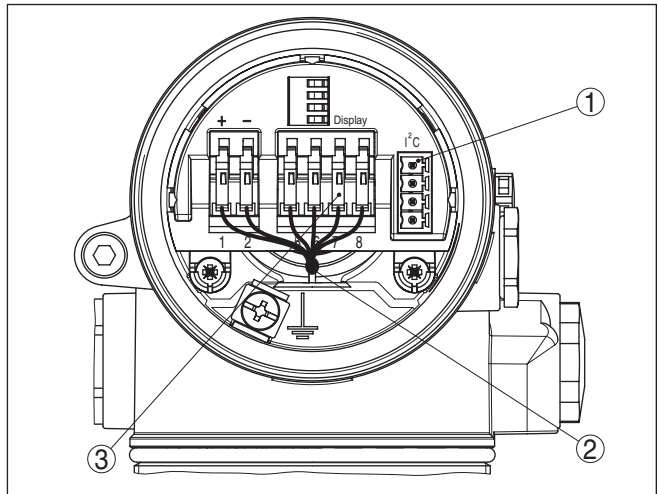

Fig. 12: Electronics compartment, double chamber housing

- 1 Plug connector for service
 2 Internal connection cable to the connection compartment
 3 Terminals for the external display and adjustment unit

Connection compartment

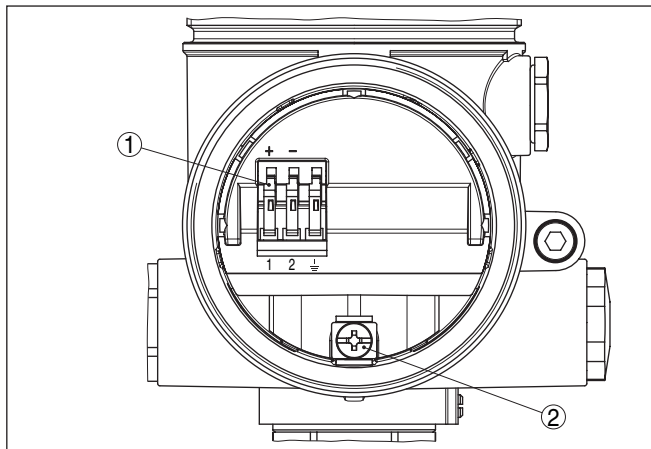

Fig. 13: Connection compartment, Ex-d double chamber housing

- 1 Spring-loaded terminals for power supply and cable screen
- 2 Ground terminal for connection of the cable screen

Wiring plan

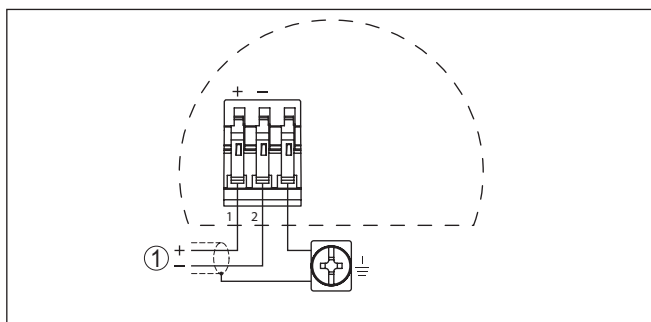

Fig. 14: Wiring plan, Ex-d double chamber housing

- 1 Voltage supply, signal output

5.6 Wiring plan, external housing with version IP 68

Overview

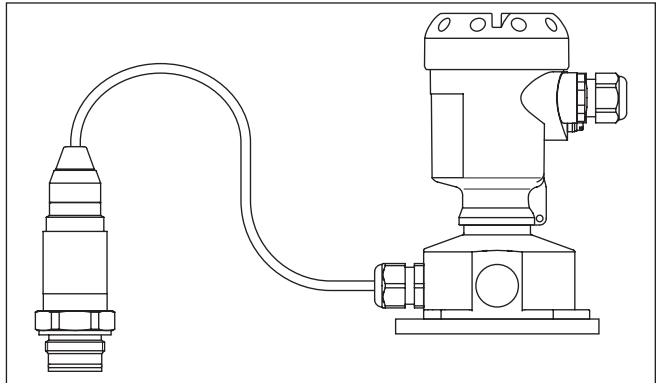

Fig. 15: IPT-1* Vers. 2.0 in IP 68 version 25 bar and axial cable outlet, external housing

Electronics and connection compartment for power supply

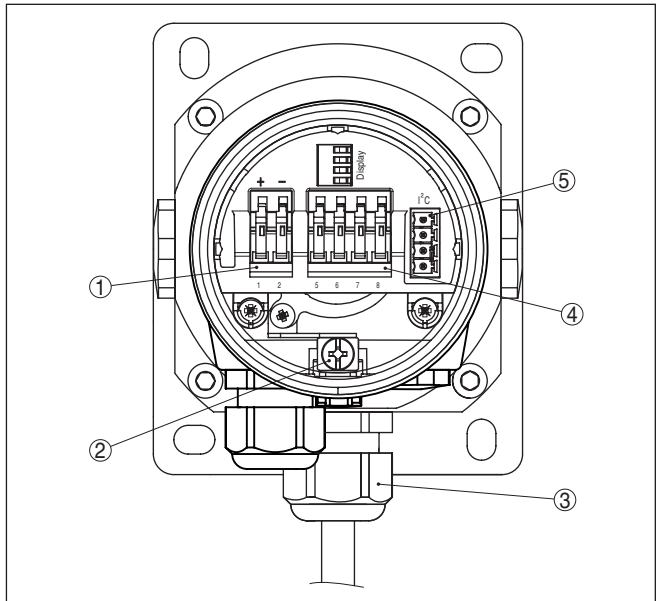

Fig. 16: Electronics and connection compartment

- 1 Spring-loaded terminals for voltage supply
- 2 Ground terminal for connection of the cable screen
- 3 Cable gland to the process component
- 4 For external display and adjustment unit, Slave sensor
- 5 Plug connector for service interface

Terminal compartment, housing socket

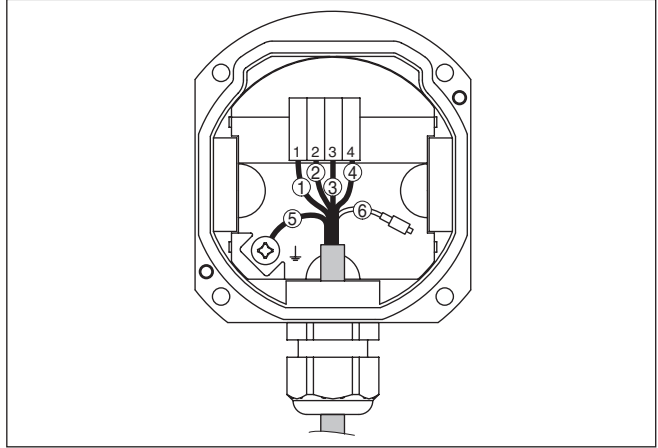

Fig. 17: Connection of the sensor in the housing base

- 1 Brown
- 2 Blue
- 3 Yellow
- 4 White
- 5 Shielding
- 6 Breather capillaries

Wiring plan external electronics

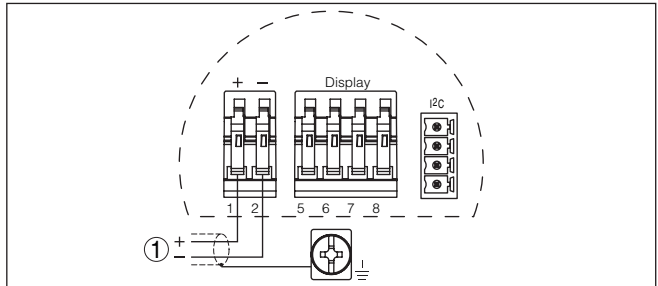

Fig. 18: Wiring plan external electronics

- 1 Voltage supply

5.7 Switch-on phase

Switch-on phase

After IPT-1* Vers. 2.0 is connected to voltage supply or after voltage recurrence, the instrument carries out a self-check for approx. 30 seconds. The following steps are carried out:

- Internal check of the electronics
- Indication of the instrument type, the firmware as well as the sensor TAGs (sensor designation)
- Status byte goes briefly to fault value

Then the current measured value will be displayed and the corresponding digital output signal will be outputted to the cable.¹⁾

¹⁾ The values correspond to the actual measured level as well as to the settings already carried out, e.g. default setting.

6 Set up with the display and adjustment module

6.1 Short description

Function/Configuration

The display and adjustment module is used for measured value display, adjustment and diagnosis. It can be mounted in the following housing versions and instruments:

- All sensors DPT-10 and IPT-1*, in the single as well as double chamber housing (optionally in the electronics or connection compartment)
- External display and adjustment unit



Note:

You can find detailed information on the adjustment in the operating instructions manual "*Display and adjustment module*".

6.2 Insert display and adjustment module

Mount/Dismount display and adjustment module

The display and adjustment module can be inserted into the sensor and removed again at any time. It is not necessary to interrupt the power supply.

Proceed as follows:

1. Unscrew the housing cover
2. Place the display and adjustment module in the desired position on the electronics (you can choose any one of four different positions - each displaced by 90°)
3. Press the display and adjustment module onto the electronics and turn it to the right until it snaps in.
4. Screw housing cover with inspection window tightly back on

Removal is carried out in reverse order.

The display and adjustment module is powered by the sensor, an additional connection is not necessary.



Fig. 19: Insert display and adjustment module



Note:

If you intend to retrofit the instrument with a display and adjustment module for continuous measured value indication, a higher cover with an inspection glass is required.

6.3 Adjustment system

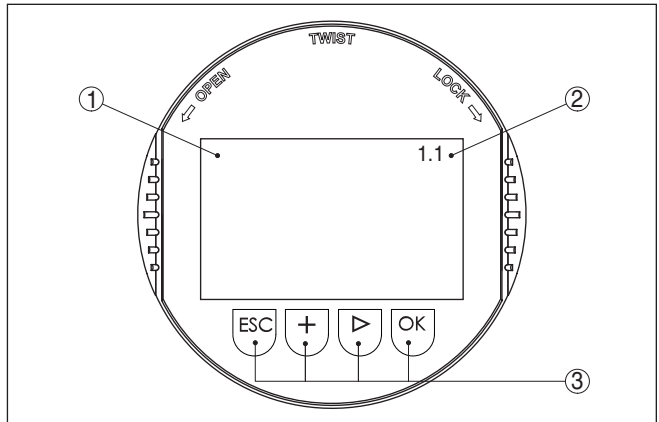

Fig. 20: Display and adjustment elements

- 1 LC display
- 2 Indication of the menu item number
- 3 Adjustment keys

Key functions

- **[OK]** key:
 - Move to the menu overview
 - Confirm selected menu
 - Edit parameter
 - Save value
- **[->]** key to select:
 - Menu change
 - Select list entry
 - Select editing position
- **[+]** key:
 - Change value of the parameter
- **[ESC]** key:
 - Interrupt input
 - Jump to next higher menu

Adjustment system

The sensor is adjusted via the four keys of the display and adjustment module. The LC display indicates the individual menu items. The functions of the individual keys are shown in the above illustration. Approx. 10 minutes after the last pressing of a key, an automatic reset to measured value indication is triggered. Any values not confirmed with **[OK]** will not be saved.

6.4 Menu schematic



Information:

Depending on the version and application, the highlighted menu windows may not always be available.

Basic adjustment

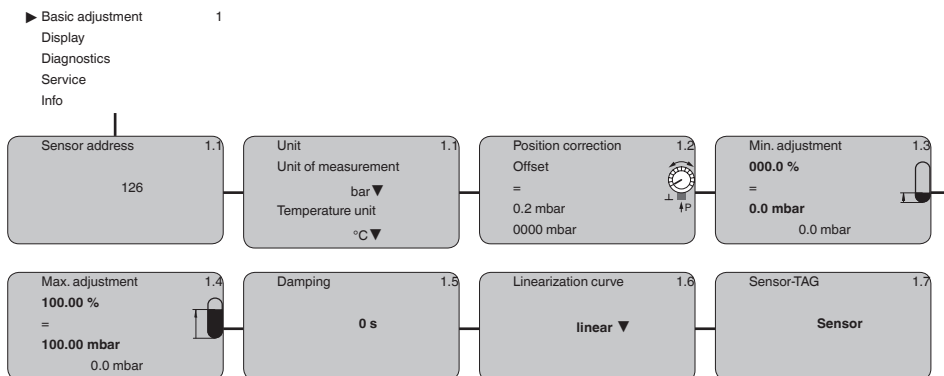

Display

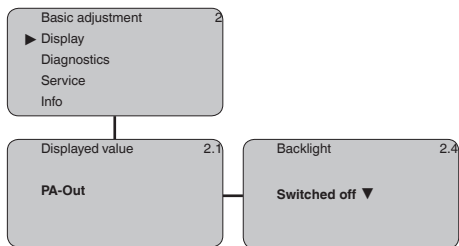

Diagnostics

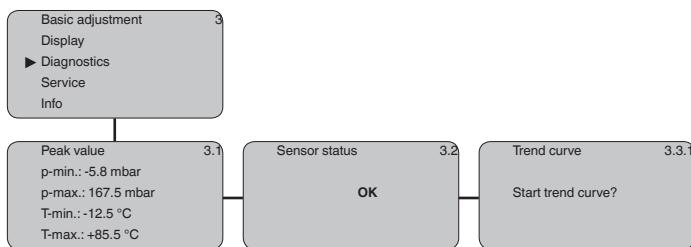

Service

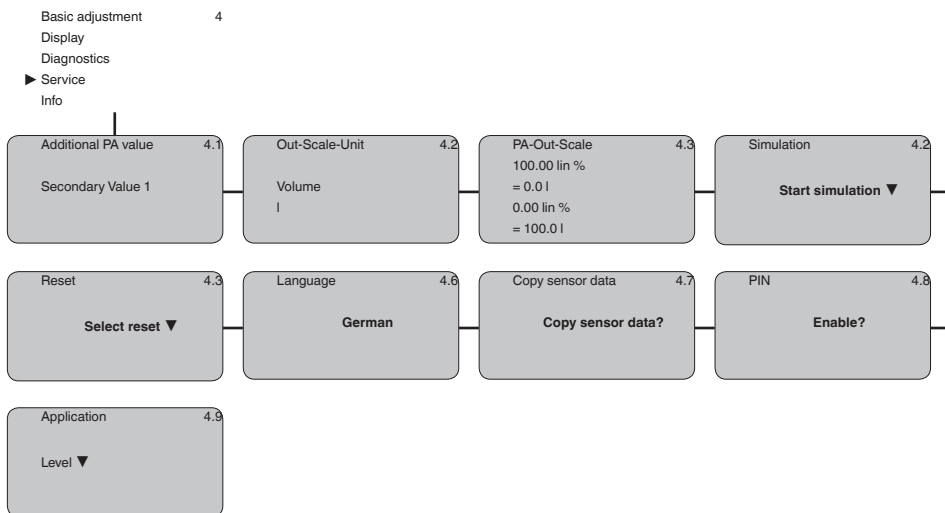

Info

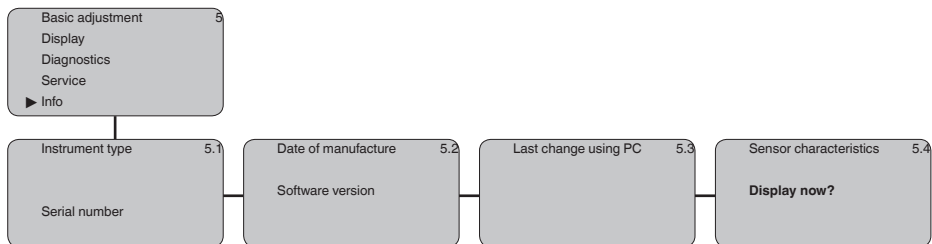

6.9 Saving the parameter adjustment data

We recommend noting the adjusted data, e.g. in this operating instructions manual, and archiving them afterwards. They are thus available for multiple use or service purposes.

If IPT-1* Vers. 2.0 is equipped with a display and adjustment module, the most important data can be read out of the sensor into the display and adjustment module. The procedure is described in the operating instructions manual "*Display and adjustment module*" in the menu item "*Copy sensor data*". The data remain there permanently even if the sensor power supply fails.

If it is necessary to exchange the sensor, the display and adjustment module is inserted into the replacement instrument and the data are written into the sensor under the menu item "*Copy sensor data*".

7 Setup with PDM

7.1 Parameter adjustment with PDM

For WIKA sensors, instrument descriptions are also available as EDDs for the adjustment program PDM. The instrument descriptions are already implemented in the current version of PDM. For older versions of PDM, a free-of-charge download is available via Internet.

Go via www.wika.com to the item "Service".

8 Maintenance and fault rectification

8.1 Maintenance

Maintenance

If the instrument is used properly, no special maintenance is required in normal operation.

In some applications, product buildup on the sensor diaphragm can influence the measuring result. Depending on the sensor and application, take precautions to ensure that heavy buildup, and especially a hardening thereof, is avoided.

Cleaning

If necessary, the transmitter has to be cleaned. In this case, make sure that the materials are resistant against the cleaning detergents.

8.2 Rectify faults

Reaction when malfunctions occur

The operator of the system is responsible for taking suitable measures to rectify faults.

Failure reasons

IPT-1* Vers. 2.0 offers maximum reliability. Nevertheless, faults can occur during operation. These may be caused by the following, e.g.:

- Sensor
- Process
- Voltage supply
- Signal processing

Fault rectification

The first measures to be taken are to check the output signals as well as to evaluate the error messages via the display and adjustment module. The procedure is described below. Further comprehensive diagnostics can be carried out on a PC with the software PACTware and the suitable DTM. In many cases, the causes can be determined and the faults rectified this way.

Checking Profibus PA

The following table describes possible errors and helps to remove them:

Error	Cause	Rectification
When an additional instrument is connected, the segment fails.	Max. supply current of the segment coupler exceeded	Measure the current consumption, reduce size of segment
Wrong presentation of the measured value in Simatic S5	Simatic S5 cannot interpret the number format IEEE of the measured value	Insert converting component from Siemens
In Simatic S7 the measured value is always presented as 0	Only four bytes are consistently loaded in the PLC	Use function component SFC 14 to load 5 bytes consistently

Error	Cause	Rectification
Measured value on the display and adjustment module does not correspond to the value in the PLC	The menu item " <i>Display - Display value</i> " is not set to " <i>PA-Out</i> "	Check values and correct, if necessary
No connection between PLC and PA network	Incorrect adjustment of the bus parameter and the segment coupler-dependent baud rate	Check data and correct, if necessary
Instrument does not appear during connection setup	Profibus DP cable pole-reversed	Check cable and correct, if necessary
	Incorrect termination	Check termination at the beginning and end points of the bus and terminate, if necessary, according to the specification
	Instrument not connected to the segment, double assignment of an address	Check and correct, if necessary



In Ex applications, the regulations for the wiring of intrinsically safe circuits must be observed.

Error messages via the display and adjustment module

Error code	Cause	Rectification
E013	no measured value available ¹⁾	- Exchange the instrument or send it in for repair
E017	Adjustment span too small	- repeat with modified values
E036	no operable sensor software	- Carry out a software update or send instrument for repair
E041	Hardware error, electronics defective	- Exchange the instrument or send it in for repair
E113	Communication conflict	- Exchange the instrument or send it in for repair

Reaction after fault rectification

Depending on the reason for the fault and the measures taken, the steps described in chapter "*Set up*" may have to be carried out again.

8.3 Instrument repair

You can find information for a return shipment under "*Service*" on our local website.

If a repair is necessary, please proceed as follows:

- Complete one form for each instrument
- If necessary, state a contamination
- Clean the instrument and pack it damage-proof

- Attach the completed form and possibly also a safety data sheet to the instrument

9 Dismounting

9.1 Dismounting steps

**Warning:**

Before dismounting, be aware of dangerous process conditions such as e.g. pressure in the vessel, high temperatures, corrosive or toxic products etc.

Take note of chapters "*Mounting*" and "*Connecting to power supply*" and carry out the listed steps in reverse order.

9.2 Disposal

The instrument consists of materials which can be recycled by specialised recycling companies. We use recyclable materials and have designed the parts to be easily separable.

WEEE directive 2002/96/EG

This instrument is not subject to the WEEE directive 2002/96/EG and the respective national laws. Pass the instrument directly on to a specialised recycling company and do not use the municipal collecting points. These may be used only for privately used products according to the WEEE directive.

Correct disposal avoids negative effects on humans and the environment and ensures recycling of useful raw materials.

Materials: see chapter "*Technical data*"

If you have no way to dispose of the old instrument properly, please contact us concerning return and disposal.

10 Supplement

10.1 Technical data

General data

Parameter, pressure	Gauge pressure, absolute pressure, vacuum
Measuring principle	Ceramic-capacitive, dry measuring cell
Communication interface	I ² C bus

Materials and weights

Material 316L corresponds to 1.4404 or 1.4435

Materials, wetted parts

- Process fitting 316L, PVDF, Alloy C-22, Alloy C-276, Duplex 1.4462, Titanium Grade 2
- Diaphragm sapphire ceramic® (99.9 % oxide ceramic)
- Joining material diaphragm/Basic element measuring cell Glass solder
- Measuring cell seal FKM (VP2/A, A+P70.16), EPDM (A+P 75.5/KW75F), FFKM (Kalrez 6375, Perlast G75S, Perlast G75B)

Material seal process fitting

- Thread G½ (EN 837) Klingersil C-4400
- Thread G1½ (DIN 3852-A) Klingersil C-4400
- M44 x 1.25 (DIN 13) FKM, FFKM, EPDM

Surface quality hygienic fittings, typ.

- Surface quality, typ. $R_a < 0.8 \mu\text{m}$

Materials, non-wetted parts

- Electronics housing Plastic PBT (polyester), Alu die-casting powder-coated, 316L
- External housing plastic PBT (Polyester), 316L
- Socket, wall mounting plate external housing plastic PBT (Polyester), 316L
- Seal between base and wall mounting plate EPDM (fixed connected)
- Seal below wall mounting plate EPDM (only with 3A approval)
- Seal, housing cover NBR (stainless steel housing), silicone (Alu/plastic housing)
- Inspection window in housing cover for display and adjustment module Polycarbonate (UL-746-C listed)
- Ground terminal 316Ti/316L
- Ohmic contact Between ground terminal and process fitting
- Connection cable between transmitter and external electronics housing with IP 68 version PUR
- Type label support on connection cable PE hard

- Connection cable with IP 68 1 bar version	PE
Weight approx.	0.8 ... 8 kg (1.764 ... 17.64 lbs), depending on process fitting

Output variable

Output signal	digital output signal, format according to IEEE-754
Sensor address	126 (default setting)
Current value	10 mA, ±0.5 mA

Dynamic behaviour output

Run-up time approx.	10 s
---------------------	------

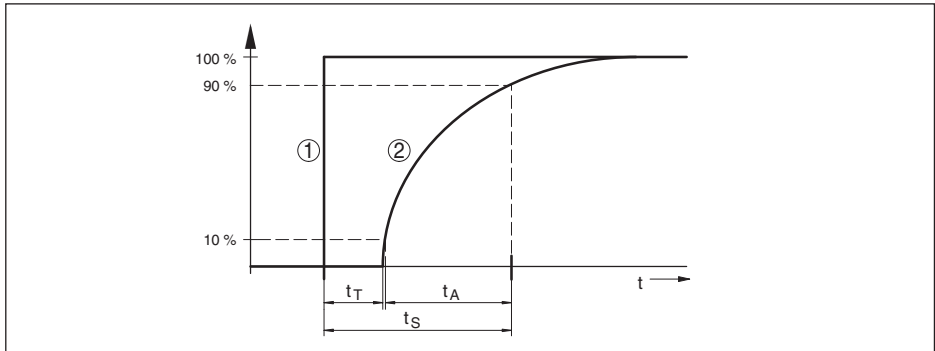

Fig. 21: Sudden change of the process variable. t_T : dead time; t_A : rise time; t_S : jump response time

- 1 Process variable
- 2 Output signal

Dead time	≤ 150 ms
Rise time	≤ 100 ms (10 ... 90 %)
Step response time	≤ 250 ms (t_i : 0 s, 10 ... 90 %)
Damping (63 % of the input variable)	0 ... 999 s, adjustable

Additional output parameter - temperature

Processing is made via output signal HART multidrop, Profibus PA and Foundation Fieldbus

Range	-50 ... +150 °C (-58 ... +302 °F)
Resolution	1 °C (1.8 °F)
Accuracy	
- in the range of 0 ... +100 °C (+32 ... +212 °F)	±3 K
- in the range of -50 ... 0 °C (-58 ... +32 °F) and +100 ... +150 °C (+212 ... +302 °F)	typ. ±4 K

Input variable

Adjustment

Adjustment range of the min./max. adjustment relating to the nominal measuring range:

- Percentage value -10 ... 110 %
- Pressure value -20 ... 120 %

Adjustment range of the zero/span adjustment relating to the nominal measuring range:

- zero -20 ... +95 %
- span -120 ... +120 %¹⁾
- Difference between zero and span max. 120 % of the nominal range

Recommended max. turn down 10 : 1 (no limitation)

Nominal measuring ranges and overload capability in bar/kPa

The specifications are only an overview and refer to the measuring cell. Limitations due to the material and version of the process fitting are possible. The specifications on the nameplate apply.

Nominal range	Overload capacity, max. pressure	Overload capacity, min. pressure
Gauge pressure		
0 ... +0.1 bar/0 ... +10 kPa	+15 bar/+1500 kPa	-0.2 bar/-20 kPa
0 ... +0.2 bar/0 ... +20 kPa	+20 bar/+2000 kPa	-0.4 bar/-40 kPa
0 ... +0.4 bar/0 ... +40 kPa	+30 bar/+3000 kPa	-0.8 bar/-80 kPa
0 ... +1 bar/0 ... +100 kPa	+35 bar/+3500 kPa	-1 bar/-100 kPa
0 ... +2.5 bar/0 ... +250 kPa	+50 bar/+5000 kPa	-1 bar/-100 kPa
0 ... +5 bar/0 ... +500 kPa	+65 bar/+6500 kPa	-1 bar/-100 kPa
0 ... +10 bar/0 ... +1000 kPa	+90 bar/+9000 kPa	-1 bar/-100 kPa
0 ... +25 bar/0 ... +2500 kPa	+130 bar/+13000 kPa	-1 bar/-100 kPa
0 ... +60 bar/0 ... +6000 kPa	+200 bar/+20000 kPa	-1 bar/-100 kPa
-1 ... 0 bar/-100 ... 0 kPa	+35 bar/+3500 kPa	-1 bar/-100 kPa
-1 ... +1.5 bar/-100 ... +150 kPa	+50 bar/+5000 kPa	-1 bar/-100 kPa
-1 ... +5 bar/-100 ... +500 kPa	+65 bar/+6500 kPa	-1 bar/-100 kPa
-1 ... +10 bar/-100 ... +1000 kPa	+90 bar/+9000 kPa	-1 bar/-100 kPa
-1 ... +25 bar/-100 ... +2500 kPa	+130 bar/+13000 kPa	-1 bar/-100 kPa
-1 ... +60 bar/-100 ... +6000 kPa	+200 bar/+20000 kPa	-1 bar/-100 kPa
-0.05 ... +0.05 bar/-5 ... +5 kPa	+15 bar/+1500 kPa	-0.2 bar/-20 kPa
-0.1 ... +0.1 bar/-10 ... +10 kPa	+20 bar/+2000 kPa	-0.4 bar/-40 kPa
-0.2 ... +0.2 bar/-20 ... +20 kPa	+30 bar/+3000 kPa	-0.8 bar/-80 kPa
-0.5 ... +0.5 bar/-50 ... +50 kPa	+35 bar/+3500 kPa	-1 bar/-100 kPa
Absolute pressure		
0 ... 0.1 bar/0 ... 10 kPa	15 bar/1500 kPa	0 bar abs.
0 ... 1 bar/0 ... 100 kPa	35 bar/3500 kPa	0 bar abs.
0 ... 2.5 bar/0 ... 250 kPa	50 bar/5000 kPa	0 bar abs.
0 ... 5 bar/0 ... 500 kPa	65 bar/6500 kPa	0 bar abs.
0 ... 10 bar/0 ... 1000 kPa	90 bar/9000 kPa	0 bar abs.

Nominal range	Overload capacity, max. pressure	Overload capacity, min. pressure
0 ... 25 bar/0 ... 2500 kPa	130 bar/13000 kPa	0 bar abs.
0 ... 60 bar/0 ... 6000 kPa	200 bar/20000 kPa	0 bar abs.

Nominal measuring ranges and overload capacity in psi

The specifications are only an overview and refer to the measuring cell. Limitations due to the material and version of the process fitting are possible. The specifications on the nameplate apply.

Nominal range	Overload capacity, max. pressure	Overload capacity, min. pressure
Gauge pressure		
0 ... +1.450 psig	+217.6 psig	-2.900 psig
0 ... +2.901 psig	+290.1 psig	-5.802 psig
0 ... +5.802 psig	+435.1 psig	-11.60 psig
0 ... +14.50 psig	+507.6 psig	-14.5 psig
0 ... +36.26 psig	+725 psig	-14.50 psig
0 ... +72.52 psig	+942.7 psig	-14.50 psig
0 ... +14.50 psig	+1305 psig	-14.50 psig
0 ... +362.6 psig	+1885 psig	-14.50 psig
0 ... +870.2 psig	+2901 psig	-14.50 psig
-14.5 ... 0 psig	+507.6 psig	-14.50 psig
-14.5 ... +21.76 psig	+725.2 psig	-14.5 psig
-1 ... +72.52 psig	+942.7 psig	-14.5 psig
-14.50 ... +145.0 psig	+1305 psig	-14.50 psig
-1 ... +362.6 psig	+1885 psig	-14.5 psig
-1 ... +870.2 psig	+2901 psig	-14.50 psig
-0.725 ... +0.725 psig	+217.6 psig	-2.901 psig
-1.450 ... +1.450 psig	+290.1 psig	-5.801 psig
-2.901 ... +2.901 psig	+435.1 psig	-11.60 psig
-7.252 ... +7.252 psig	+507.6 psig	-14.50 psig
Absolute pressure		
0 ... 1.405 psi	217.6 psi	0 psi
0 ... 14.5 psi	507.6 psi	0 psi
0 ... 36.26 psi	725.2 psi	0 psi
0 ... 72.52 psi	942.7 psi	0 psi
0 ... 145.0 psi	1305 psi	0 psi
0 ... 362.6 psi	1885 psi	0 psi
0 ... 870.2 psi	2901 psi	0 psi

Reference conditions and actuating variables (according to DIN EN 60770-1)

Reference conditions according to DIN EN 61298-1

- Temperature	+15 ... +25 °C (+59 ... +77 °F)
- Relative humidity	45 ... 75 %
- Air pressure	860 ... 1060 mbar/86 ... 106 kPa (12.5 ... 15.4 psig)
Determination of characteristics	Limit point adjustment according to IEC 61298-2
Characteristic curve	Linear
Reference installation position	upright, diaphragm points downward
Influence of the installation position	< 0.2 mbar/20 Pa (0.003 psig)

Deviation determined according to the limit point method according to IEC 60770²⁾

Applies to **digital** interfaces (HART, Profibus PA, Foundation Fieldbus) as well as to **analogue** current output 4 ... 20 mA. Specifications refer to the set span. Turn down (TD) is the ratio nominal measuring range/set span.

Deviation

- Turn down 1 : 1 up to 5 : 1 < 0.075 %
- Turn down > 5 : 1 < 0.015 % x TD

Deviation with absolute pressure measuring range 0.1 bar

- Turn down 1 : 1 up to 5 : 1 < 0.25 %
 - Turn down > 5 : 1 < 0.05 % x TD
-

Influence of the product or ambient temperature

Thermal change zero signal and output span

Applies to the **digital** signal output (HART, Profibus PA, Foundation Fieldbus) as well as to **analogue** current output 4 ... 20 mA and refers to the set span. Turn down (TD) is the ratio nominal measuring range/set span.

Thermal change zero signal and output span, reference temperature 20 °C (68 °F):

- In the compensated temperature range 0 ... +100 °C (+32 ... +212 °F) < (0.05 % + 0.1 % x TD)
- Outside the compensated temperature range < (0.05 % + 0.15 % x TD)

Thermal change zero signal and output span with absolute pressure measuring range 0.1 bar, reference temperature 20 °C (68 °F):

- In the compensated temperature range 0 ... +100 °C (+32 ... +212 °F) < (0.1 % + 0.1 % x TD)
- Outside the compensated temperature range < (0.15 % + 0.15 % x TD)

Thermal change, current output

Applies also to the **analogue** 4 ... 20 mA current output and refers to the set span.

Thermal change, current output < 0.05 %/10 K, max. < 0.15 %, each with -40 ... +80 °C (-40 ... +176 °F)

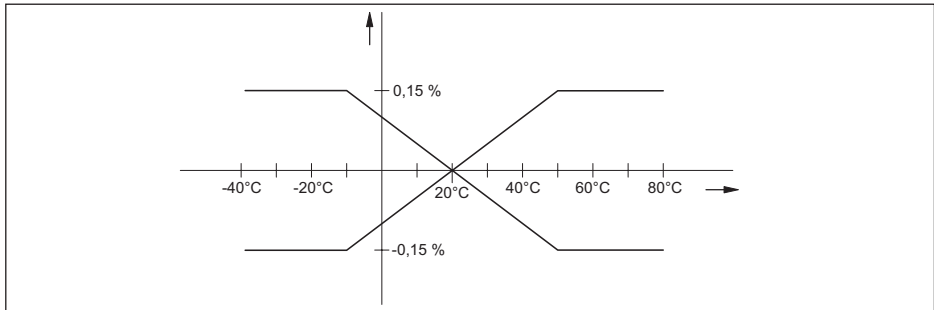

Fig. 22: Thermal change, current output

Long-term stability (according to DIN 16086 and IEC 60770-1)

Applies to **digital** HART interface as well as to **analogue** current output 4 ... 20 mA under reference conditions. Specifications refer to the set span. Turn down (TD) is the relation nominal measuring range/set span.

Long-term drift of the zero signal:

- For one year < 0.05 % x TD
- For five years < 0.1 % x TD
- For ten years < 0.2 % x TD

Ambient conditions

Ambient, storage and transport temperature

- Standard version -40 ... +80 °C (-40 ... +176 °F)
- Versions IP 66/IP 68 (1 bar) and IP 68 (25 bar), connection cable PUR -20 ... +80 °C (-4 ... +176 °F)
- Version IP 66/IP 68 (1 bar), connection cable PE -20 ... +60 °C (-4 ... +140 °F)

Process conditions

The specifications of the pressure stage and product temperature are used as an overview. The specifications on the type label are applicable.

Pressure stage, process fitting

- Thread 316L, depending on connection PN 10, PN 60, PN 160
- Thread Aluminium PN 25
- Thread PVDF PN 10
- Hygienic fittings 316L, depending on connection PN 6, PN 10, PN 25, PN 40 (PN 40 only with DRD and DIN 11851)
- Flange 316L PN 16, PN 40, 150 lbs, 300 lbs, 600 lbs
- Flange with extension 316L without PN specification, PN 16, PN 40 or 150 lbs, 300 lbs, 600 lbs
- Flange flattened on both sides 316L PN 10
- Flange PVDF PN 16

Product temperature depending on the measuring cell seal³⁾

Measuring cell seal	Product temperature - standard version	Product temperature - version with extended temperature range
FKM (VP2/A)	-20 ... +120 °C (-4 ... +248 °F)	-20 ... +150 °C (-4 ... +302 °F)
FKM (A+P 70.16)	-40 ... +120 °C (-40 ... +248 °F)	-
EPDM (A+P 75.5/KW75F)	-40 ... +120 °C (-40 ... +248 °F) 1 h: 140 °C/284 °F cleaning temperature	-40 ... +150 °C (-40 ... +302 °F)
EPDM (ET 7056)	-40 ... +120 °C (-40 ... +248 °F) 1 h: 140 °C/284 °F cleaning temperature	-
FFKM (Kalrez 6375)	-20 ... +120 °C (-4 ... +248 °F)	-20 ... +150 °C (-4 ... +302 °F)
FFKM (Perlast G75S)	-15 ... +120 °C (-4 ... +248 °F)	-15 ... +150 °C (5 ... +302 °F)
FFKM (Perlast G75B)	-15 ... +120 °C (-4 ... +248 °F)	-15 ... +150 °C (5 ... +302 °F)

Vibration resistance mechanical vibrations with 4 g and 5 ... 100 Hz⁴⁾

Shock resistance Acceleration 100 g/6 ms⁵⁾

Electromechanical data - version IP 66/IP 67

Cable entry/plug⁶⁾

- Single chamber housing
 - 1 x cable gland M20 x 1.5 (cable: ø 5 ... 9 mm), 1 x blind plug M20 x 1.5
or:
 - 1 x closing cap ½ NPT, 1 x blind plug ½ NPT
or:
 - 1 1/2" plug (depending on the version), 1 1/2" blind stopper M20 1/2" x 1.5
or:
 - 2 x blind plug M20 x 1,5
- Double chamber housing
 - 1 x cable entry M20 x 1.5 (cable: ø 5 ... 9 mm), 1 x blind plug M20 x 1.5; plug M12 x 1 for the external display and adjustment unit (optional)
or:
 - 1 x closing cap ½ NPT, 1 x blind plug ½ NPT, plug M12 x 1 for the external display and adjustment unit (optional)
or:
 - 1 x plug (depending on the version), 1 x blind plug M20 x 1.5; plug M12 x 1 for the external display and adjustment unit (optional)
or:
 - 2 x blind stoppers M20 x 1.5; plug M12 x 1 for the external display and adjustment unit (optional)

Spring-loaded terminals for wire cross-section < 2.5 mm² (AWG 14)

Electromechanical data - version IP 68

Connection cable between IP 68 instrument and external housing:

– Configuration	four wires, one suspension wire, one breather capillary, screen braiding, metal foil, mantle
– Wire cross-section	0.5 mm ² (AWG 20)
– Wire resistance	< 0.036 Ω/m (0.011 Ω/ft)
– Standard length	5 m (16.40 ft)
– Max. length	180 m (590.5 ft)
– Min. bending radius at 25 °C/77 °F	25 mm (0.985 in)
– Diameter approx.	8 mm (0.315 in)
– Colour	Blue
Cable entry/plug ⁷⁾	
– External housing	– 1 x cable gland M20 x 1.5 (cable: ø 5 ... 9 mm), 1 x blind plug M20 x 1.5 or: – 1 \square x plug (depending on the version), 1 \square x blind stopper M20 \square x1.5
Spring-loaded terminals for wire cross-section up to	2.5 mm ² (AWG 14)

Display and adjustment module

Voltage supply and data transmission	through the sensor
Indication	LC display in dot matrix
Adjustment elements	4 keys
Protection rating	
– unassembled	IP 20
– mounted into the sensor without cover	IP 40
Material	
– Housing	ABS
– Inspection window	Polyester foil

Voltage supply

Operating voltage	
– Non-Ex instrument	9 ... 32 V DC
– Ex-ia instrument	9 ... 24 V DC
– Ex-d instrument	14 ... 32 V DC
Operating voltage with illuminated display and adjustment module	
– Non-Ex instrument	18 ... 32 V DC
– Ex-ia instrument	18 ... 24 V DC
– Ex-d instrument	18 ... 32 V DC
Max. number of sensors on the DP/PA segment coupler non-Ex/Ex	32/10

Electrical protective measures

Protection rating	
– Housing, standard	IP 66/IP 67 ⁸⁾

– Process component in IP 68 version	IP 68 (25 bar)
– External housing	IP 65
Overvoltage category	III
Protection class	II

Approvals

Depending on the version, instruments with approvals can have different technical data. For these instruments, please note the corresponding approval documents. They are included in the scope of delivery.

10.2 Information on Profibus PA

Instrument master file

The instrument master file (GSD) contains the characteristic data of the Profibus PA instrument. These data are, e.g. the permissible transmission rates as well as information on diagnostics values and the format of the measured value outputted by the PA instrument.

A bitmap file is also provided for the Profibus network planning tool. This file is installed automatically when the GSD file is integrated. The bitmap file is used for symbolic indication of the PA instrument in the configuration tool.

Ident number

Each Profibus instrument gets an unambiguous ident number (ID number) from the Profibus user organisation (PNO). This ID number is also included in the name of the GSD file. For IPT-1* Vers. 2.0 the ID number is **0 x 076F(hex)** and the GSD file **BR__076F.GSD**. As an option to this manufacturer-specific GSD file, PNO provides also a general so-called profile-specific GSD file. For IPT-1* Vers. 2.0 you have to use the general GSD file **PA139701.GSD**. If the general GSD file is used, the sensor must be set to the profile-specific ident number via the DTM software. By default, the sensor operates with the manufacturer-specific ID number.



Note:

When using the profile-specific GSD file, the PA-OUT value as well as the temperature value are transmitted to the PLC (see block diagram "*Cyclical data traffic*").

Cyclical data traffic

The master class 1 (e.g. PLC) cyclically reads out measured values from the sensor during operation. The below block diagram below shows which data can be accessed by the PLC.

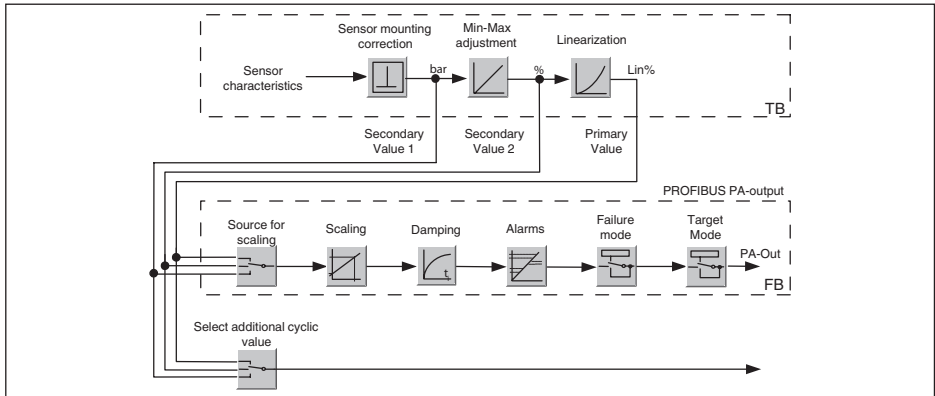

Fig. 23: IPT-1* Vers. 2.0: Block diagram with AI (PA-OUT) value and Additional Cyclic Value

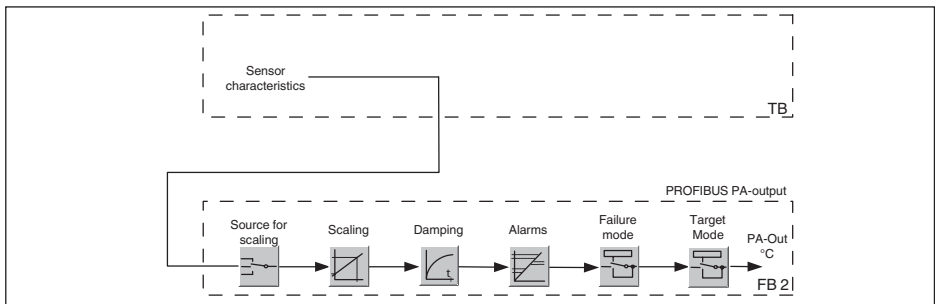

Fig. 24: IPT-1* Vers. 2.0: Block diagram with temperature value

Module of the PA sensors

For the cyclic data traffic, IPT-1* Vers. 2.0 provides the following modules:

- AI (PA-OUT)
 - PA-OUT value of the FB1 after scaling
- Temperature
 - PA-OUT value of the FB2 after scaling
- Additional Cyclic Value
 - Additional cyclical value (depending on the source)
- Free Place
 - This module must be used if a value should not be used in the data telegram of the cyclical data traffic (e.g. replacement of the temperature and Additional Cyclic Value)

A maximum of three modules can be active. By means of the configuration software of the Profibus master you can determine the configuration of the cyclical data telegram with these modules. The procedure depends on the respective configuration software.

Tip:
i The modules are available in two versions:

- Short for Profibus master supporting only one "Identifier Format" byte, e.g. Allen Bradley

- Long for Profibus master only supporting the "Identifier Format" byte, e.g. Siemens S7-300/400

Examples of telegram configuration

In the following you will see how the modules can be combined and how the appendant data telegram is structured.

Example 1 (standard setting) with pressure value, temperature value and additional cyclical value:

- AI (PA-OUT)
- Temperature
- Additional Cyclical Value

Byte-No.	1	2	3	4	5	6	7	8	9	10	11	12	13	14	15
Format	IEEE-754-Floating point value				Status	IEEE-754-Floating point value				Status	IEEE-754-Floating point value				Status
Value	PA-OUT (FB1)				Status (FB1)	Temperature (FB2)				Status (FB2)	Additional Cyclical Value				Status

Fig. 25: Telegram configuration example 1

Example 2 with pressure value and temperature value without additional cyclical value:

- AI (PA-OUT)
- Temperature
- Free Place

Byte-No.	1	2	3	4	5	6	7	8	9	10
Format	IEEE-754-Floating point value				Status	IEEE-754-Floating point value				Status
Value	PA-OUT (FB1)				Status (FB1)	Temperature (FB2)				Status (FB2)

Fig. 26: Telegram configuration example 2

Example 3 with pressure value and additional cyclical value without temperature value:

- AI (PA-OUT)
- Free Place
- Additional Cyclical Value

Byte-No.	1	2	3	4	5	6	7	8	9	10
Format	IEEE-754-Floating point value				Status	IEEE-754-Floating point value				Status
Value	PA-OUT (FB1)				Status (FB1)	Additional Cyclical Value				Status

Fig. 27: Telegram configuration example 3

Data format of the output signal

Byte4	Byte3	Byte2	Byte1	Byte0
Status	Value (IEEE-754)			

Fig. 28: Data format of the output signal

The status byte corresponds to profile 3.0 "Profibus PA Profile for Process Control Devices" coded. The status "Measured value OK" is coded as 80 (hex) (Bit7 = 1, Bit6 ... 0 = 0).

The measured value is transferred as a 32 bit floating point number in the IEEE-754 format.

Byte n								Byte n+1								Byte n+2								Byte n+3							
Bit 7	Bit 6	Bit 5	Bit 4	Bit 3	Bit 2	Bit 1	Bit 0	Bit 7	Bit 6	Bit 5	Bit 4	Bit 3	Bit 2	Bit 1	Bit 0	Bit 7	Bit 6	Bit 5	Bit 4	Bit 3	Bit 2	Bit 1	Bit 0	Bit 7	Bit 6	Bit 5	Bit 4	Bit 3	Bit 2	Bit 1	Bit 0
VZ	2 ⁷	2 ⁶	2 ⁵	2 ⁴	2 ³	2 ²	2 ¹	2 ⁰	2 ¹	2 ²	2 ³	2 ⁴	2 ⁵	2 ⁶	2 ⁷	2 ⁸	2 ⁹	2 ¹⁰	2 ¹¹	2 ¹²	2 ¹³	2 ¹⁴	2 ¹⁵	2 ¹⁶	2 ¹⁷	2 ¹⁸	2 ¹⁹	2 ²⁰	2 ²¹	2 ²²	2 ²³
Sign Bit	Exponent							Significant							Significant							Significant									

$$\text{Value} = (-1)^{\text{VZ}} \cdot 2^{(\text{Exponent} - 127)} \cdot (1 + \text{Significant})$$

Fig. 29: Data format of the measured value

Coding of the status byte associated with the PA output value

Status code	Description according to Profibus standard	Possible cause
0 x 00	bad - non-specific	Flash-Update active
0 x 04	bad - configuration error	<ul style="list-style-type: none"> - Adjustment error - Configuration error with PV-Scale (PV-Span too small) - Unit irregularity - Error in the linearization table
0 x 0C	bad - sensor failure	<ul style="list-style-type: none"> - Hardware error - Converter error - Leakage pulse error - Trigger error
0 x 10	bad - sensor failure	<ul style="list-style-type: none"> - Measured value generation error - Temperature measurement error
0 x 1f	bad - out of service constant	"Out of Service" mode switched on
0 x 44	uncertain - last unstable value	Failsafe replacement value (Failsafe-Mode = "Last value" and already valid measured value since switching on)
0 x 48	uncertain substitute set	<ul style="list-style-type: none"> - Switch on simulation - Failsafe replacement value (Failsafe-Mode = "Fsafe value")
0 x 4c	uncertain - initial value	Failsafe replacement value (Failsafe-Mode = "Last valid value" and no valid measured value since switching on)
0 x 51	uncertain - sensor; conversion not accurate - low limited	Sensor value < lower limit
0 x 52	uncertain - sensor; conversion not accurate - high limited	Sensor value > upper limit
0 x 80	good (non-cascade) - OK	OK
0 x 84	good (non-cascade) - active block alarm	Static revision (FB, TB) changed (10 sec. active, after the parameter of the static category has been written)
0 x 89	good (non-cascade) - active advisory alarm - low limited	Lo-Alarm
0 x 8a	good (non-cascade) - active advisory alarm - high limited	Hi-Alarm
0 x 8d	good (non-cascade) - active critical alarm - low limited	Lo-Lo-Alarm
0 x 8e	good (non-cascade) - active critical alarm - high limited	Hi-Hi-Alarm

10.3 Dimensions

The double chamber housings are only available for Ex-d version with instruments with 4 ... 20 mA signal output.

Plastic housing

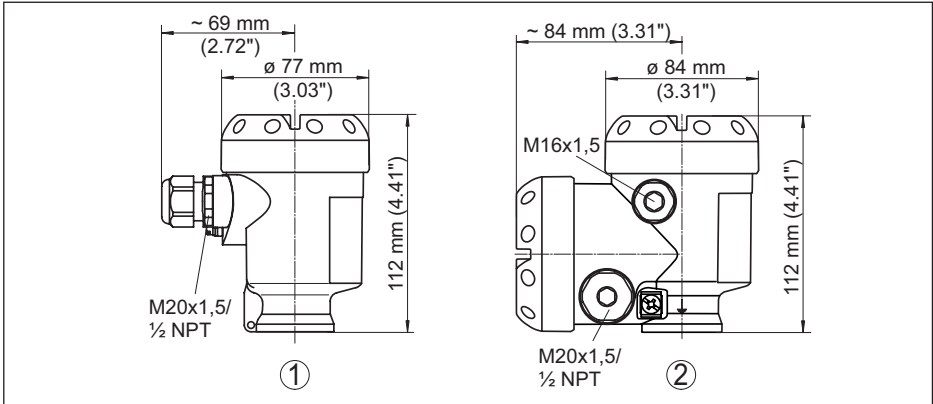

Fig. 30: Housing versions in protection IP 66/IP 68 (0.2 bar) - with integrated display and adjustment module the housing is 9 mm/0.35 in higher

- 1 Single chamber version
- 2 Double chamber version

Aluminium housing

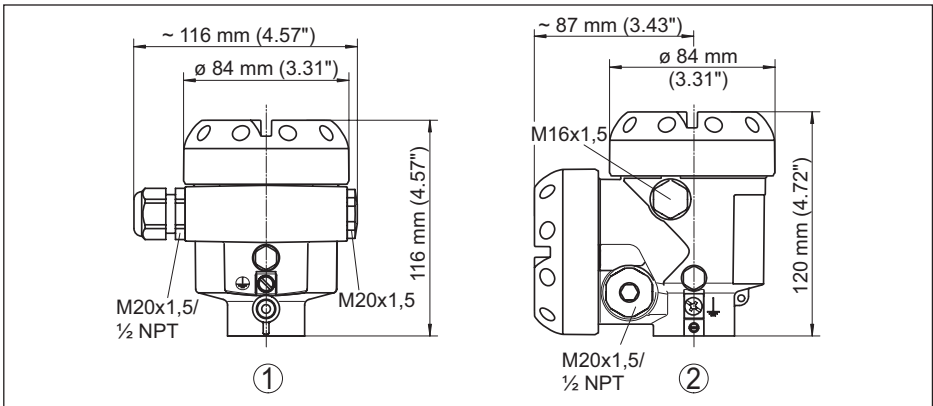

Fig. 31: Housing versions in protection IP 66/IP 68 (0.2 bar) - with integrated display and adjustment module the housing is 9 mm/0.35 in higher

- 1 Single chamber version
- 2 Double chamber version

Stainless steel housing

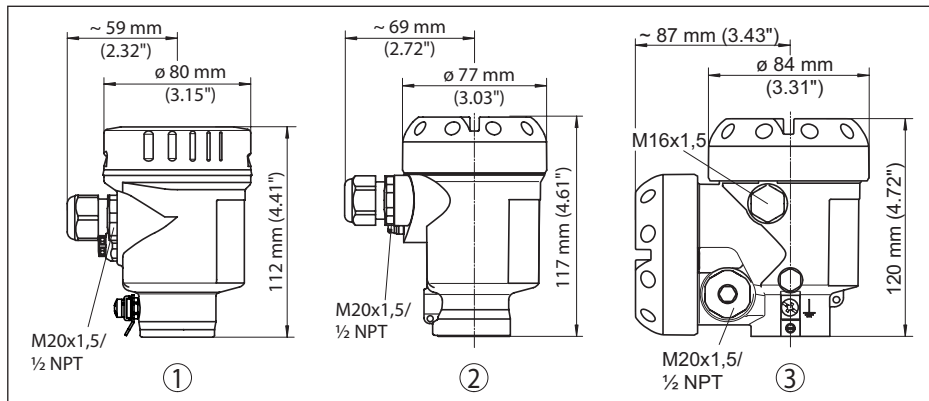

Fig. 32: Housing versions in protection IP 66/IP 68 (0.2 bar) - with integrated display and adjustment module the housing is 9 mm/0.35 in higher

- 1 Single chamber version, electropolished
- 2 Single chamber version, precision casting
- 3 Double chamber version, precision casting

External housing with IP 68 version

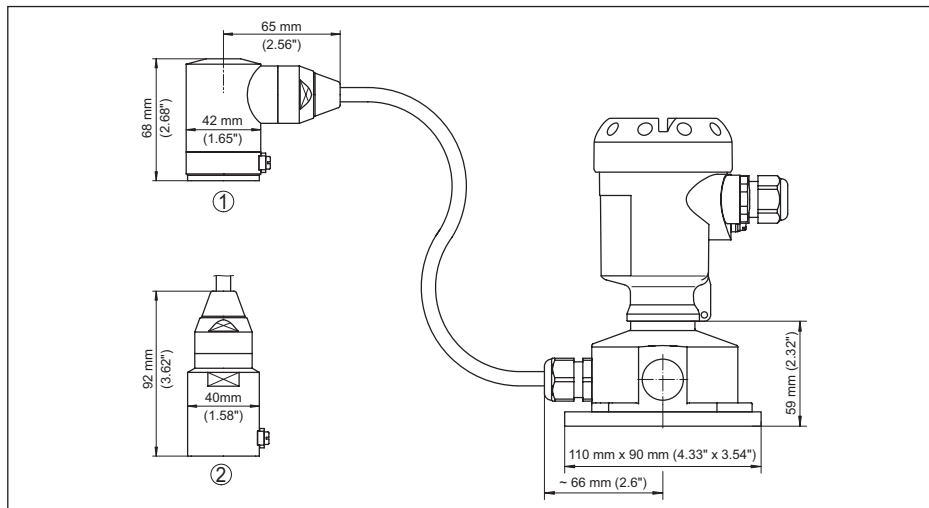

Fig. 33: IP 68 version with external housing

- 1 Lateral cable outlet
- 2 Axial cable outlet

IPT-1* Vers. 2.0 - standard version

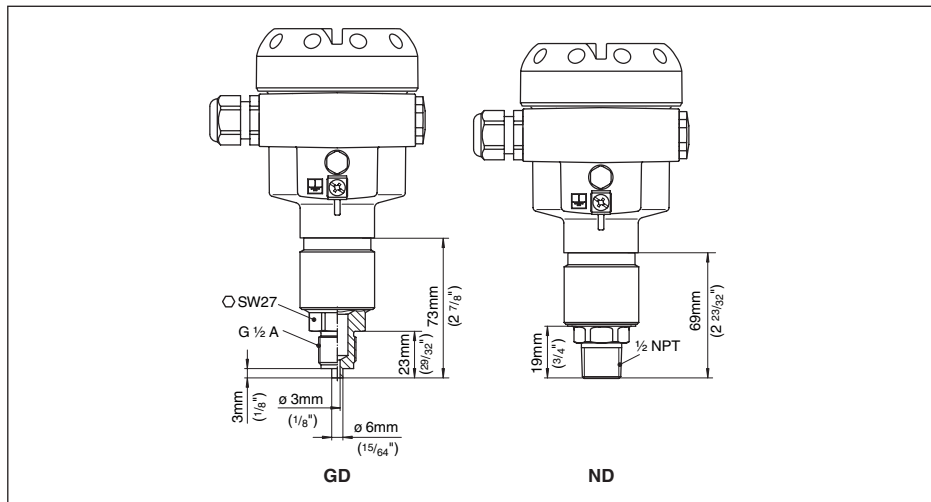

Fig. 34: IPT-1* Vers. 2.0 GD = G $\frac{1}{2}$ A manometer connection EN 837, ND = $\frac{1}{2}$ NPT

IPT-1* Vers. 2.0 - front-flush diaphragm

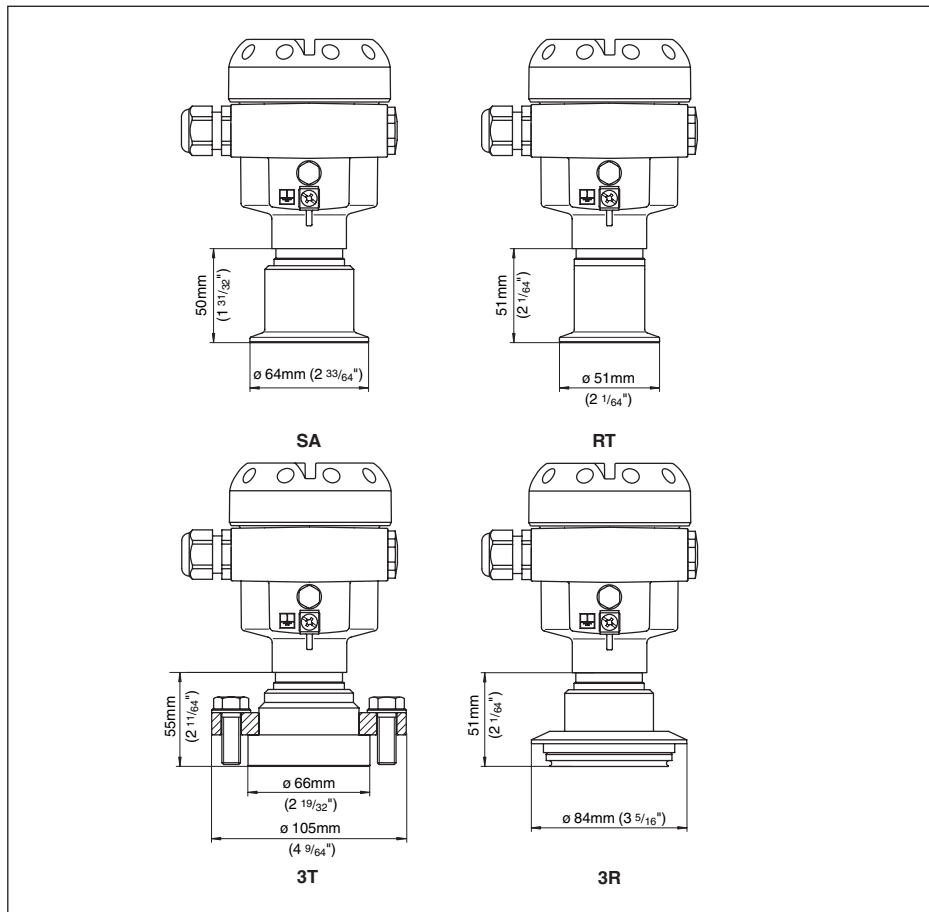

Fig. 35: IPT-1* Vers. 2.0 SA = Tri-Clamp 2", RT = Tri-Clamp 1½", 3T = DRD, 3R = Varivent Form F

INDEX**A**

Application area 8

C

Check signal 29

Connection compartment 19

D

Data format of the output signal 43

Disposal 32

E

Electronics and connection compartment 16

Electronics compartment, double chamber housing 18

F

Fault rectification 29

Functional principle 8

G

GSD 41

I

Installation position 11

M

Moisture 11

P

PA modules 42

Pressure compensation 11

Process conditions 11

Profibus ident number 41

R

Read out measurement data 41

Recycling 32

S

Seal concept 8

Status byte 44

T

Telegram configuration 43

Temperature limits 12

Type plate 7

W

WEEE directive 32

Wiring plan

– Double chamber housing 18

– External electronics 21

– Single chamber housing 16

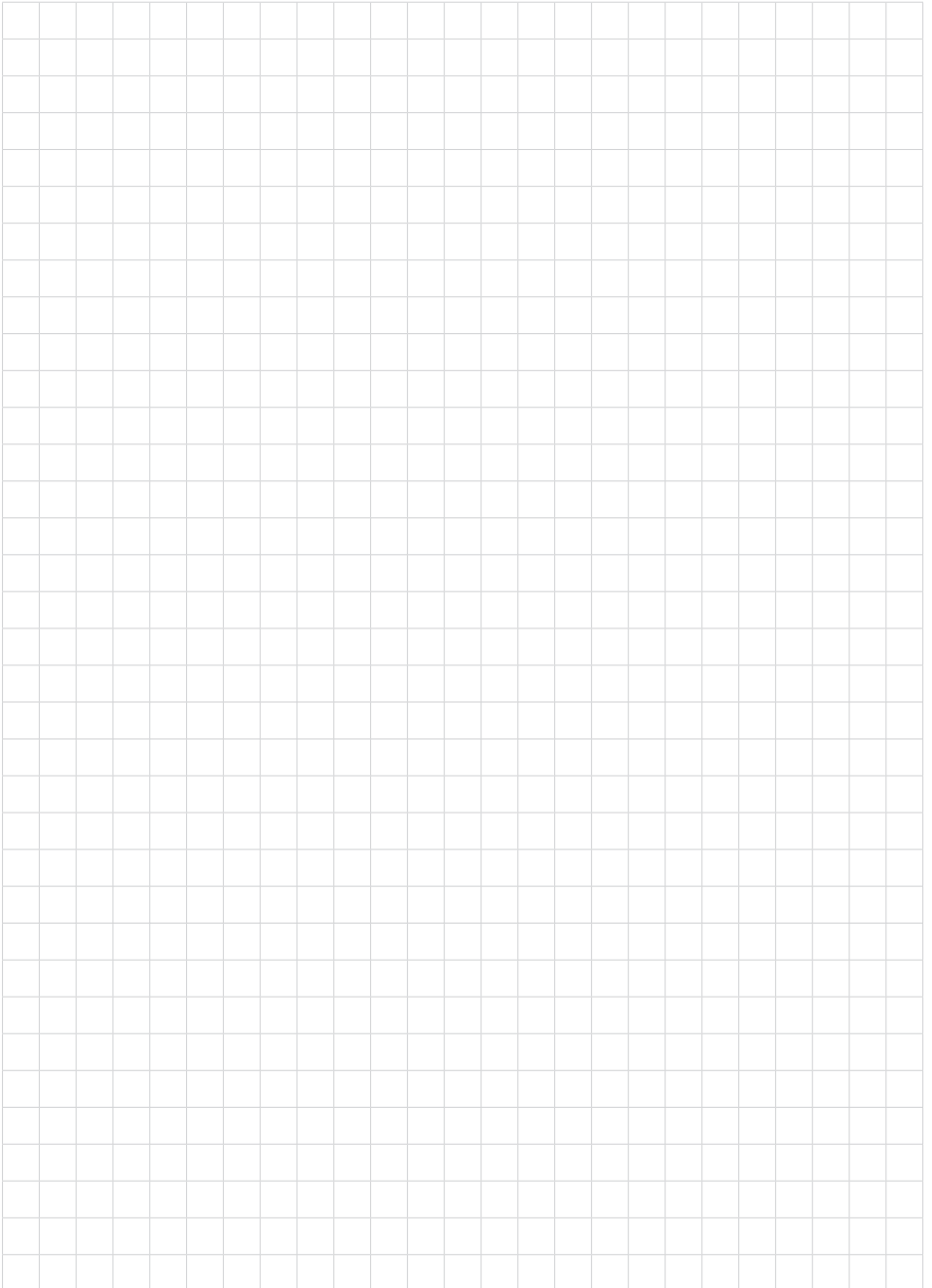

Printing date:



All statements concerning scope of delivery, application, practical use and operating conditions of the sensors and processing systems correspond to the information available at the time of printing.



WIKA Alexander Wiegand SE & Co. KG

Alexander-Wiegand-Straße 30

63911 Klingenberg

Germany

Phone (+49) 9372/132-0

Fax (+49) 9372 132-406

E-mail: info@wika.de

www.wika.de

41225-EN-130628